



EN Operating instructions.pages 1 to 8
Original

5 Set-up and maintenance
5.1 Functional testing.6
5.2 Maintenance6

6 Disassembly and disposal
6.1 Disassembly.6
6.2 Disposal6

7 Appendix
7.1 EU Declaration of conformity7
7.2 Declaration of installation.7

Content

1 About this document
1.1 Function1
1.2 Target group: authorised qualified personnel.1
1.3 Explanation of the symbols used1
1.4 Appropriate use1
1.5 General safety instructions1
1.6 Warning about misuse2
1.7 Exclusion of liability2

2 Product description
2.1 Ordering code2
2.2 Special versions.3
2.3 Destination and use3
2.4 Operating principle of the checking device3
2.5 AV 15, AV 20, AV 25 with checking device.3
2.6 AV 18, AV 21, AV 28 without checking device4
2.7 Technical data4

3 Mounting
3.1 General mounting instructions4
3.2 Models with checking device5
3.3 Possible installation positions5
3.4 Locking pin chambers - various variants5
3.5 Dimensions5

4 Electrical connection
4.1 General information for electrical connection.6
4.2 Pin assignment6

1. About this document

1.1 Function
This operating instructions manual provides all the information you need for the mounting, set-up and commissioning to ensure the safe operation and disassembly of the safety switchgear. The operating instructions must be available in a legible condition and a complete version in the vicinity of the device.

1.2 Target group: authorised qualified personnel
All operations described in this operating instructions manual must be carried out by trained specialist personnel, authorised by the plant operator only.

Please make sure that you have read and understood these operating instructions and that you know all applicable legislations regarding occupational safety and accident prevention prior to installation and putting the component into operation.

The machine builder must carefully select the harmonised standards to be complied with as well as other technical specifications for the selection, mounting and integration of the components.

1.3 Explanation of the symbols used

 **Information, hint, note:**
This symbol is used for identifying useful additional information.

 **Caution:** Failure to comply with this warning notice could lead to failures or malfunctions.
Warning: Failure to comply with this warning notice could lead to physical injury and/or damage to the machine.

1.4 Appropriate use
The products described in these operating instructions are developed to execute safety-related functions as part of an entire plant or machine. It is the responsibility of the manufacturer of a machine or plant to ensure the correct functionality of the entire machine or plant.

The safety switchgear must be exclusively used in accordance with the versions listed below or for the applications authorised by the manufacturer. Detailed information regarding the range of applications can be found in the chapter "Product description".

1.5 General safety instructions
The user must observe the safety instructions in this operating instructions manual, the country-specific installation standards as well as all prevailing safety regulations and accident prevention rules.

 Further technical information can be found in the Schmersal catalogues or in the online catalogue on the Internet: www.schmersal.net.

The information contained in this operating instructions manual is provided without liability and is subject to technical modifications. There are no residual risks, provided that the safety instructions as well as the instructions regarding mounting, commissioning, operation and maintenance are observed.

1.6 Warning about misuse



In case of improper use or manipulation of the safety switch-gear, personal hazards or damages to machinery or plant components cannot be excluded when safety switchgear is used.

1.7 Exclusion of liability

We shall accept no liability for damages and malfunctions resulting from defective mounting or failure to comply with this operating instructions manual. The manufacturer shall accept no liability for damages resulting from the use of unauthorised spare parts or accessories.

For safety reasons, invasive work on the device as well as arbitrary repairs, conversions and modifications to the device are strictly forbidden; the manufacturer shall accept no liability for damages resulting from such invasive work, arbitrary repairs, conversions and/or modifications to the device.

2. Product description

2.1 Ordering code

This operating instructions manual applies to the following types:

AV 15 ①②③④⑤ ⑥⑦45°N⑧

| No. | Option | Description |
|-----|--------------------|--|
| ① | L / R | Left-hand model / right-hand model with traction link |
| ② | H/H92/H105 B/B2 | Lever H65, H92, H105 Bearing block B, B2 without auxiliary contact |
| ③ | K | with auxiliary contact |
| ④ | IP41 | Protection class IP20 Protection class IP41 without cable gland |
| ⑤ | E4 E1 | Cable gland M20 Cable entry (5 holes) |
| ⑥ | X... | X-dimension = 11.5, 20, 30, 40, 45 mm |
| ⑦ | U D L/R | Inclined section at locking bolt 45° bottom-side Inclined section at locking bolt 45° cover-side Inclined section at locking bolt 45° left-hand side / right-hand side |
| ⑧ | GB215 | back-side mounting holes additional frontal mounting holes M8 |

AV 18 ①②③④⑤ ⑥⑦45°N⑧

| No. | Option | Description |
|-----|--------------------|--|
| ① | L / R | Left-hand model / right-hand model with traction link |
| ② | H/H92/H105 B/B2 | Lever H65, H92, H105 Bearing block B, B2 without auxiliary contact |
| ③ | K | with auxiliary contact |
| ④ | IP41 | Protection class IP20 Protection class IP41 without cable gland |
| ⑤ | E4 E1 | Cable gland M20 Cable entry (5 holes) |
| ⑥ | X... | X-dimension = 11.5, 20, 30, 40, 45 mm |
| ⑦ | U D L/R | Inclined section at locking bolt 45° bottom-side Inclined section at locking bolt 45° cover-side Inclined section at locking bolt 45° left-hand side / right-hand side |
| ⑧ | GB215 | back-side mounting holes additional frontal mounting holes M8 |

AV 20 ①②③④⑤-⑥⑦

| No. | Option | Description |
|-----|--------------------|--|
| ① | L / R | Left-hand model / right-hand model with traction link |
| ② | H/H92/H105 B/B2 | Lever H65, H92, H105 Bearing block B, B2 without cable gland |
| ③ | E4 E2 | Cable gland M20 Cable entry (4 holes) |
| ④ | X... | X-dimension = 11.5, 20, 30, 40, 45 mm |
| ⑤ | U D R L | Inclined section at locking bolt 45° bottom-side Inclined section at locking bolt 45° cover-side Inclined section at locking bolt 45° right-hand side Inclined section at locking bolt 45° left-hand side |
| ⑥ | 2509 | Metal triangular release key |
| ⑦ | GB215 | back-side mounting holes additional frontal mounting holes M8 |

AV 21 ①②③④⑤⑥

| No. | Option | Description |
|-----|--------------------|--|
| ① | L / R | Left-hand model / right-hand model with traction link |
| ② | H/H92/H105 B/B2 | Lever H65, H92, H105 Bearing block B, B2 without cable gland |
| ③ | E4 E2 | Cable gland M20 Cable entry (4 holes) |
| ④ | X... | X-dimension = 11.5, 20, 30, 40, 45 mm |
| ⑤ | U D L/R | Inclined section at locking bolt 45° bottom-side Inclined section at locking bolt 45° cover-side Inclined section at locking bolt 45° left-hand side / right-hand side |
| ⑥ | GB215 | back-side mounting holes additional frontal mounting holes M8 |

AV 25 ①②③④⑤45°N⑥

| No. | Option | Description |
|-----|---------------|--|
| ① | L R | Left-hand model right-hand model without auxiliary contact |
| ② | K | with auxiliary contact without cable gland |
| ③ | E4 E1 | Cable gland M20 Cable entry (5 holes) |
| ④ | X... | X-dimension = 11.5, 20, 30, 40, 45 mm |
| ⑤ | U D L/R | Inclined section at locking bolt 45° bottom-side Inclined section at locking bolt 45° cover-side Inclined section at locking bolt 45° left-hand side / right-hand side |
| ⑥ | GB215 | back-side mounting holes additional frontal mounting holes M8 |

AV 28 ①②③④⑤⑥45°N⑥

| No. | Option | Description |
|-----|--------|---|
| ① | L | Left-hand model |
| | R | right-hand model |
| ② | K | without auxiliary contact |
| | K | with auxiliary contact |
| ③ | E4 | without cable gland |
| | E4 | Cable gland M20 |
| ④ | E1 | Cable entry (5 holes) |
| | X... | X-dimension = 11.5, 20, 30, 40, 45 mm |
| ⑤ | U | Inclined section at locking bolt 45° bottom-side |
| | D | Inclined section at locking bolt 45° cover-side |
| | L/R | Inclined section at locking bolt 45° left-hand side / right-hand side |
| ⑥ | | back-side mounting holes |
| | GB215 | additional frontal mounting holes M8 |



Only if the information described in this operating instructions manual are realised correctly, the safety function and therefore the compliance with the Lift Directive is maintained.

2.2 Special versions

For special versions, which are not listed in the order code below 2.1, these specifications apply accordingly, provided that they correspond to the standard version.

2.3 Destination and use

The construction and operation of the following locking devices for lift shaft doors comply with the requirements of the Lift Directive, as well as the Safety Regulations for the Construction and Installation of Passenger Lifts, Goods Lifts and Service Lifts.

Door locking devices

| | |
|-------|---|
| AV 15 | for single-leaf shaft doors |
| AV 20 | |
| AV 25 | for two-leaf shaft doors |
| AV 18 | component of a locking device for shaft doors |
| AV 21 | |
| AV 28 | |

Provided that it is installed in compliance with the regulations, the safety locking device will keep the shaft door shut and locked, according to the control command. When the shaft door is intentionally open, the locking devices AV 15, 20 and 25 prevent any unnoticed lowering of the locking pins which would, as a result, cause the locking contacts to close whilst the shaft door is open. In the case of the AV 18, 21 and 28 models, this feature is achieved by virtue of the construction of the locking devices.

2.4 Operating principle of the checking device

Should the locking cam be engaged before the shaft door is closed, the checking device mechanism will operate. The unlocking magnet (12) sticks to the magnet plate, thus mechanically preventing the movement of the locking pin. The locking and auxiliary contacts remain open. When the shaft door is closed, the unlocking magnet (12) and the door magnet (17) are positioned in such a way that their identical poles are facing one-another, thus repelling each other. The locking pin (2) is released and penetrates the shaft door (16). The locking contact (10) is closed and the auxiliary contact (4) is open.

2.5 AV 15, AV 20, AV 25 with checking device

When the shaft door is open and the locking cam fallen, the locking pin (2) is retracted due to either tension in direction A on the traction link (5) or to the roller arm swinging in direction B.

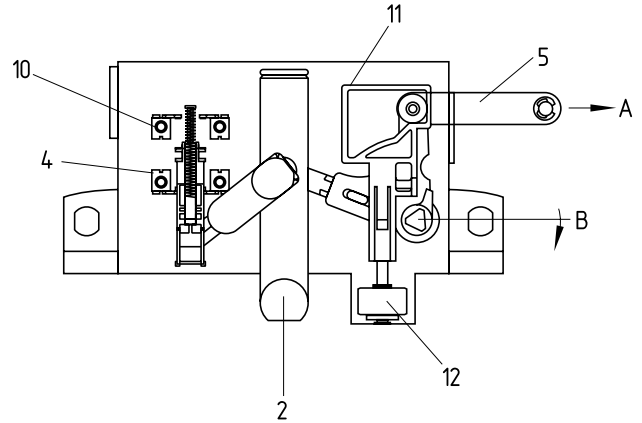

With the locking cam engaged, the roller arm and/or the traction link (5) are released and the locking pin (2) penetrates the shaft door (16).

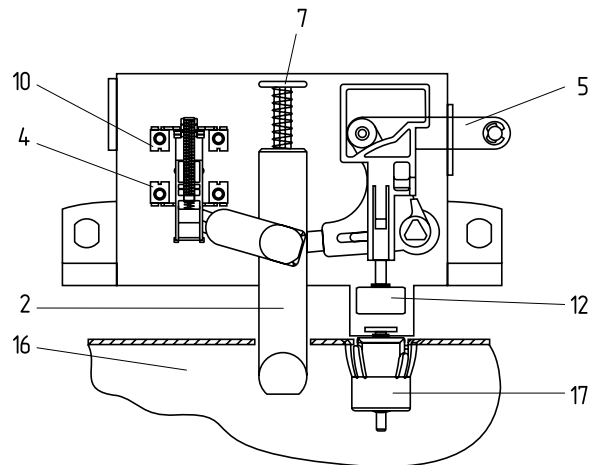

Key

- 2 Locking pin
- 4 Auxiliary contact
- 5 Pull Strap
- 7 Spring
- 10 Locking bolt contact
- 11 Locking element
- 12 Offset roller lever
- 16 Shaft door
- 17 Anti-faulty closing protection

Operating instructions

Door locking devices

AV 15, AV 18, AV 20, AV 21, AV 25, AV 28

2.6 AV 18, AV 21, AV 28 without checking device

When the shaft door is open and the locking cam fallen, the locking pin (2) is retracted due to either tension in direction A on the traction link (4) or to the roller arm swinging in direction B. The locking contact (7) is open and the auxiliary contact (8) is closed.

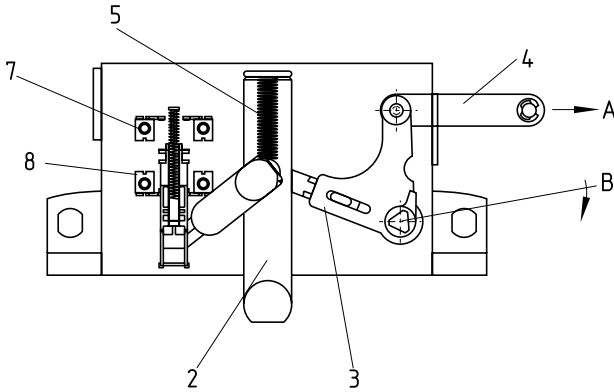

When the shaft door is closed and the locking cam engaged, the locking pin (2) penetrates the shaft door (1). The locking contact (7) is closed and the auxiliary contact (8) is open.

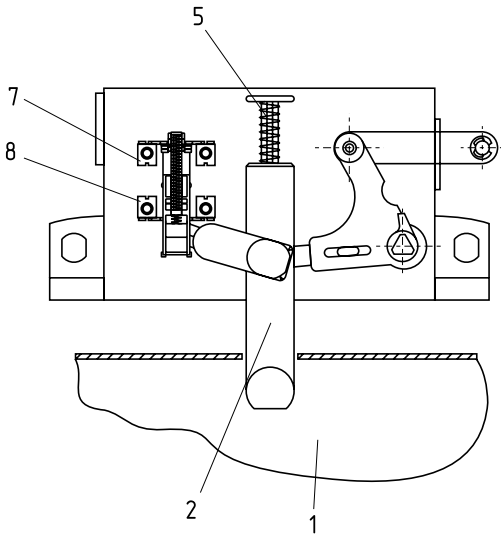

Key

- 1 Shaft door
- 2 Locking pin
- 3 Angle roller lever
- 4 Pull Strap
- 5 Spring
- 7 Locking bolt contact
- 8 Auxiliary contact

2.7 Technical data

| | |
|-----------------------|--|
| Standards: | EN 81-20, EN 81-50 |
| Enclosure: | |
| - AV 20/21: | glass-fibre reinforced thermo-plastic, self-extinguishing, |
| - AV 15/18, AV 25/28: | light alloy die-casting |
| Protection class: | |
| - AV 20/21: | IP54 |
| - AV 15/18, AV 25/28: | IP20 |
| Locking pin: | brass Ø 18 mm |
| Contact material: | Silver |
| Contact type: | Change-over contact with double break, with galvanically separated contact bridges |

| | |
|---|--|
| Rated impulse withstand voltage U_{imp} : | 6 kV |
| Rated insulation voltage U_i : | |
| - AV 20/21: | 500 VAC |
| - AV 15/18, AV 25/28: | 400 VAC |
| Thermal test current I_{th} : | 10 A |
| Utilisation category to EN 60947-5-1: | AC-15: 2 A / 230 VAC DC-13: 1 A / 24 VDC |
| Rated operating current/voltage I_e/U_e to EN 81: | 2 A / 230 VAC 2 A / 200 VDC |
| Max. fuse rating: | 6 A (slow blow) |
| Emergency release: | using triangular key M5 to DIN 22417 |
| Permanent magnet: | |
| - AV 20, AV 15, AV 25: | with checking device (ceramic-oxide magnet with high coercive field strength, flux variation depending on the temperature 0.2 %/°C, which is, however, reversible.) |
| Ambient temperature: | - 15 °C ... + 70 °C |

3. Mounting

3.1 General mounting instructions

Two mounting holes are provided for fixing the enclosure. The door locking devices AV 20 and AV 21 are double-insulated. The use of an earth wire is not authorised.

The door locking devices AV 15/18/25/28 are not double-insulated, which means that a protective conductor needs to be connected.

Drill a suitable engagement hole for the locking pin in the door vane, this should be sufficiently large so that the movement of the locking pin is not impaired. Two 9 x 11 mm slotted holes are provided for the fixing of the locking device.

AV 20 FLH.....

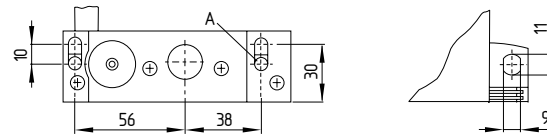

Key A adjustable M6 nut

To guarantee the effective engagement-depth of at least 7mm at the departure of the lift car and to guarantee the positive operation of the means used to prove the position of the locking element, the following depths the locking bolt need to engage into or behind the locking part:

| | AV 15, AV 20, AV 25 | AV 18, AV 21, AV 28 |
|---|-------------------------|-------------------------|
| While operating | ≥ 16 mm (max. 21 mm) | ≥ 12 mm (max. 21 mm) |
| In the case of open circuit of the lock contact | ≥ 13 mm | ≥ 8 mm |



The relevant requirements of the standard ISO 12100 must be observed.



The door locking devices and, where necessary, door magnet (which protects against unintentional closure) are to be secured by suitable means (with the use of tamperproof screws, by bonding, drilling out screw heads, pin locking) on the guard system and secured to prevent them from shifting.

3.2 Models with checking device

A suitably drilled hole of max. 23 mm diameter is required for the fixing of the door magnet.

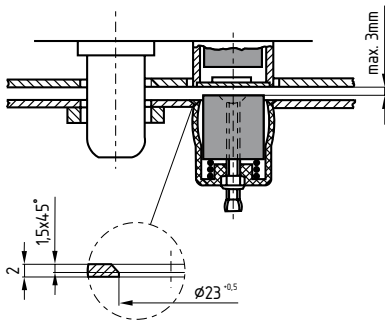

The drilled hole for the magnet protection tube must be sufficiently large (min. 27 mm).

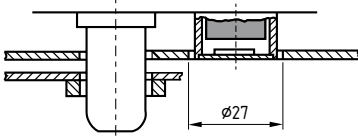

The distance between the centres of the door magnet and the counter-magnet must be no greater than 2 mm. The adjustable distance between the door magnet and the counter magnet must be no greater than 3 mm.

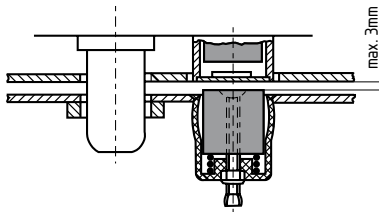

The with checking device

- works on a magnetic principle. Therefore, there should be no excessive iron in the vicinity.
- has a high resistance to galling, therefore, do not oil!

3.3 Possible installation positions

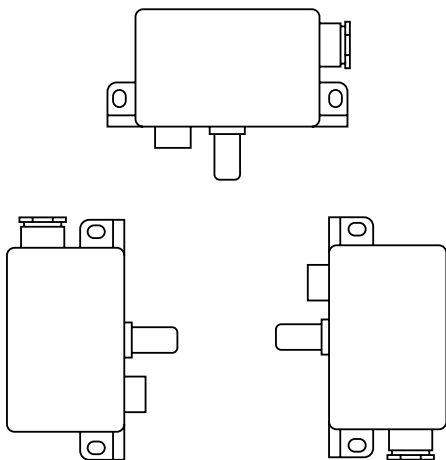

3.4 Locking pin chambers - various variants

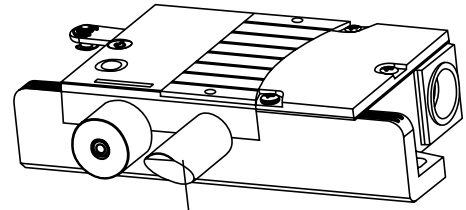

Adjustment

- Before adjusting the roller arm, gently loosen the locking screw: do not force!
- The distance between the door magnet and the counter magnet is adjustable (max. 3 mm).
- If the door falls by > 6 mm the locking device is to be re-adjusted!
- Triangular release M5 for quick adjustment on rear of housing.



Opening the middle cover of the AV 20/21 invalidates the guarantee!

3.5 Dimensions

All measurements in mm.

AV 15, AV 18, AV 20, AV 21 for single-leaf shaft doors,
Left-hand model with traction link
(right-hand model is mirror image)

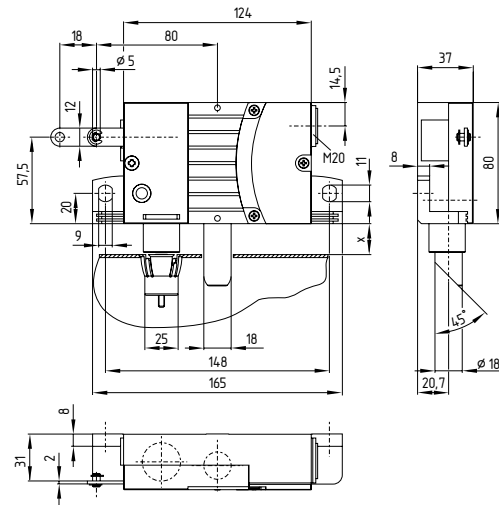

Left-hand model with roller lever H
(right-hand model is mirror image)

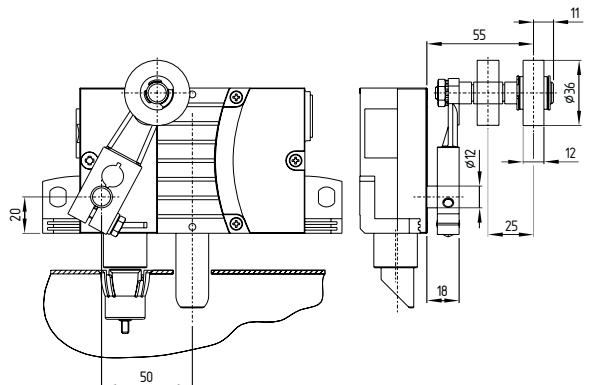

Operating instructions Door locking devices

AV 15, AV 18, AV 20, AV 21, AV 25, AV 28

Left-hand model with pedestal B
(right-hand model is mirror image)

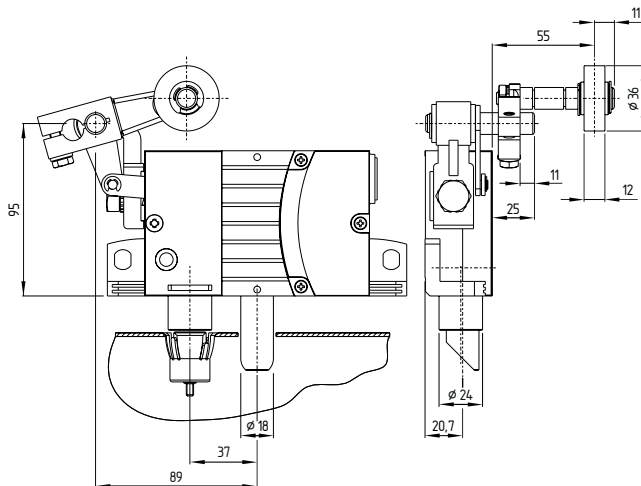

Left-hand model with pedestal B2
(right-hand model is mirror image)

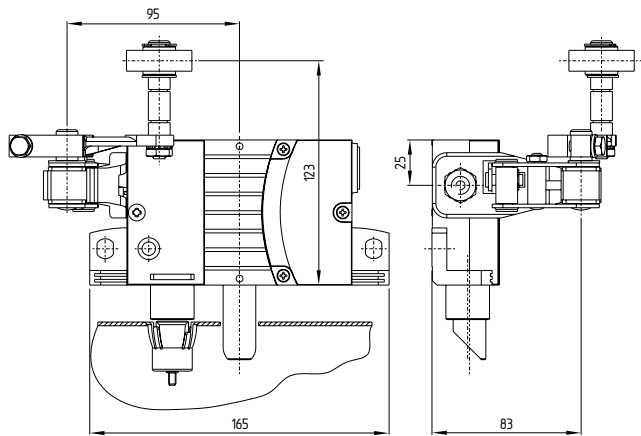

i The AV 20 is shown above, AV 15 has the same dimensions, AV 18 and AV 21 have the same dimensions, however without checking device.

AV 25, AV 28 for two-leaf shaft doors,

Right-hand model with auxiliary contact and cable gland E1
(left-hand model is mirror image)

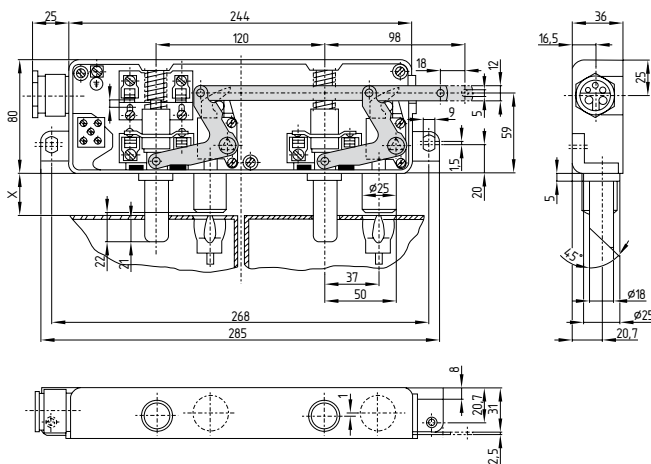

i The AV 25 is shown above, AV 28 has the same dimensions, however without checking device

4. Electrical connection

4.1 General information for electrical connection



The electrical connection may only be carried out by authorised personnel in a de-energised condition.

Appropriate cable glands with a suitable degree of protection are to be used.

4.2 Pin assignment

AV 15/18, 25/28 standard 1 NC / optional 1 NO
AV 20/21 standard 1 NC / 1 NO

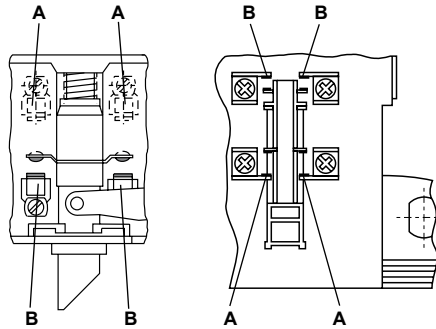

Key

- A Auxiliary contact
- B Locking bolt contact

5. Set-up and maintenance

5.1 Functional testing

The safety function of the safety components must be tested. The following conditions must be previously checked and met:

1. Fitting of the solenoid interlock and the actuator
2. Check the integrity of the cable entry and connections
3. Check the switch enclosure for damage

5.2 Maintenance

A regular visual inspection and functional test, including the following steps, is recommended:

1. Check for tight installation of the actuator and the switch
2. Remove particles of dust and soiling
3. Check cable entry and connections



Adequate measures must be taken to ensure protection against tampering either to prevent tampering of the safety guard, for instance by means of replacement actuators.

Damaged or defective components must be replaced.

6. Disassembly and disposal

6.1 Disassembly

The safety switchgear must be disassembled in a de-energised condition only.

6.2 Disposal

The safety switchgear must be disposed of in an appropriate manner in accordance with the national prescriptions and legislations.

7. Appendix

7.1 EU Declaration of conformity

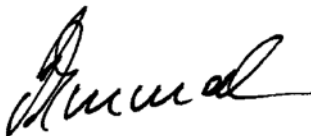
| EU Declaration of conformity | |  | |
|--|--|---|----------------|
| Original | K.A. Schmersal GmbH & Co. KG Möddinghofe 30 42279 Wuppertal Germany Internet: www.schmersal.com | | |
| We hereby certify that the hereafter described components both in their basic design and construction conform to the applicable European Directives. | | | |
| Name of the component: | AV 15, AV 18, AV 20, AV 21, AV 25, AV 28 | | |
| Type: | See ordering code | | |
| Year of construction: | See identification plate | | |
| Description of the component: | Door locking devices | | |
| Relevant Directives: | | Valid up to | Valid as of |
| | | April 19, 2016 | April 20, 2016 |
| | Low Voltage Directive | 2006/95/EC | 2014/35/EU |
| | Lift Directive | 95/16/EC | 2014/33/EU |
| | RoHS-Directive | 2014/65/EU | 2014/65/EU |
| Applied standards: | EN 81-20: 2014, EN 81-50: 2015 | | |
| Notified body for the prototype test: | TÜV SÜD Industrie Service GmbH Zentralbereich Fördertechnik Abteilung Aufzüge und Sicherheitsbauteile Gottlieb-Daimler-Str. 7 70794 Filderstadt ID n°: 0036 | | |
| EU-prototype test certificate: | EU-DL 59 (AV 15), EU-DL 76 (AV 18), EU-DL 528 (AV 20), EU-DL 529 (AV 21), EU-DL 60 (AV 25), EU-DL 75 (AV 28) | | |
| Place and date of issue: | Wuppertal, April 8, 2016 | | |
| |  Authorised signature Philip Schmersal Managing Director | | |

AV15-28-C-EN



The currently valid declaration of conformity and prototype test certificate can be downloaded from the internet at www.schmersal.net.



7.2 Declaration of installation

| | |
|--|---------------------------|
| The above described device is installed in elevator: | |
| Serial no.: | Construction year: |
| Installation firm: | |
| _____ Stamp and signature: | |

K. A. Schmersal GmbH & Co. KG
Möddinghofe 30, D - 42279 Wuppertal
Postfach 24 02 63, D - 42232 Wuppertal

Phone: +49 - (0)2 02 - 64 74 - 0
Telefax: +49 - (0)2 02 - 64 74 - 1 00
E-Mail: info@schmersal.com
Internet: <http://www.schmersal.com>